

Edwards Model 150 / 160 / 300 Pump Maintenance Manual

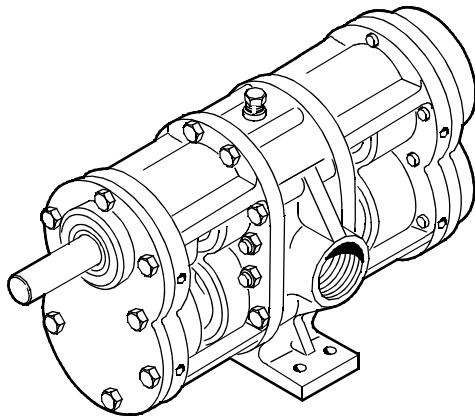
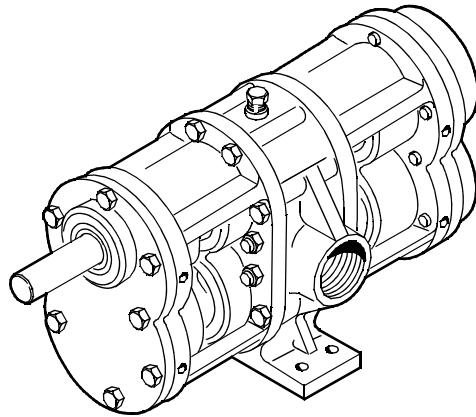
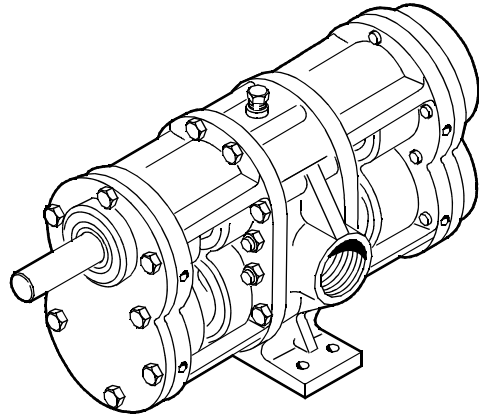

AURORA® EDWARDS SERIES

Contents

Safety		
General Precautions	iii	
Warnings and Cautions	iii	
Warnings	iii	
Cautions	iv	
1 General		
Introduction	1-1	
2 Maintenance		
Consumable Materials	2-1	
Lubrication	2-2	
Troubleshooting	2-2	
Removal	2-3	
Disassembly	2-4	
General Practice	2-4	
Disassembly Procedure	2-4	
Cleaning	2-6	
Inspection	2-7	
Repair and Replacement	2-7	
Assembly	2-8	
General Practice	2-8	
Assembly Procedure	2-8	
Replacement	2-12	
3 Installation		
Inspection	3-1	
Unpacking	3-1	
Repacking	3-1	
Storage	3-1	
Installation	3-2	
Clean Pump	3-2	
Mount Pump	3-2	
Prepare Foundation	3-4	
Level Pump Skid	3-5	
Grout Pump Skid	3-5	
Check Driver Rotation	3-6	
Align Couplings	3-7	
Piping	3-9	
Strainers	3-10	
Overpressure Protection	3-10	
Pre-Startup Checks	3-11	
4 Parts		
Warranty		

General Precautions

The following are general safety precautions not related to any specific procedure. Personnel must understand and apply these precautions during both operation and maintenance of the pump.

Do Not Operate Pump Without Ear Protection. The pump has heat-treated steel timing gears, which can be very noisy when operated above 900 rpm.

Be Aware of High Heat When Unit Is Running. Both operating and maintenance personnel must observe all safety precautions at all times. To avoid injury, always de-energize the input power sources and lock-out or red-tag the controller. Let the pump cool before handling.

Be Aware of Chemical Hazards. Maintenance personnel must observe all safety precautions while working with the chemicals used in cleaning agents.

Warnings and Cautions

The following warnings and cautions relate to specific procedures in this manual. They are repeated here for emphasis.

Warnings



Do not perform maintenance using this manual if the model number on the pump is not 150-348 or the serial number is not _____. Performing maintenance using the wrong manual could result in pump failure or personal injury.



To avoid injury, always de-energize the input driver and lock-out or red-tag the controller. Let the pump cool before removing.



Overpressurization of the pump can cause equipment failure, resulting in personal injury.



Do not order parts using this manual if the model number on the pump is not 150-348 or the serial number is not _____. Using parts ordered from the wrong manual could result in pump failure or personal injury.

Cautions



Do not hammer on pump endcase. This will cause gasket sealing surface damage, resulting in leaks.

Use shaft protector between puller tip and shaft face to prevent distortion of shaft center.



Never hammer directly on pump drive shaft. This will cause the rotor assembly to become misaligned, resulting in incorrect internal clearances. Also, hammering on the shaft ends may damage the shaft centers.



Never dip or soak packings, rubber, plastic, or teflon parts in “dry” cleaning solvent. Wipe with clean, lint-free cloth. Solvent can react with material and result in severe damage or destruction of parts.



Do not use excessive force when installing seals. This could damage the seals, causing them to leak. Use approved tools available from Edwards.



Do not rotate rotor assemblies until bearings have been installed and adjusted. Damage to rotors and liners may occur.



Make sure liners fit into counterbore on endcase, and that they can be fully seated into the endcase counterbore without using excessive force. Damage to endcases and liners could occur.



Support ends of shafts axially with a jaw puller on the endcase when installing ball bearings to avoid damaging liners and rotors. The jaw puller should be used on the shaft end opposite the end where the bearing is being installed. Use a shaft protector to avoid damaging shaft center.



Do not overtighten bearing adjusting nut setscrews. Excessive bearing preload may result, causing bearing damage.



Rotary pumps have close running clearances. Thus, clean piping is a must. Dirt, grit, weld bead or scale, flushed from an unclean piping system, will damage and may stall the pump. Flush the system thoroughly before connecting piping to pump.

Introduction

The Edwards Model 150, Model 160 and Model 300 pumps (Figure 1-1) are standard-duty high-speed gear-driven positive-displacement rotary pumps with gear-type rotors. The pumps are self-priming. Edwards rotary pumps are available in many configurations. While they may look alike, there may be significant differences from one pump to another. Differences include construction material, sealing method, rotor type, etc

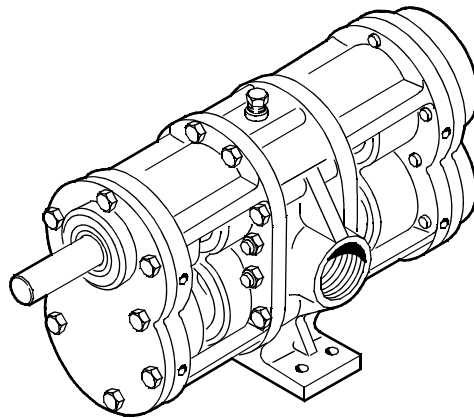



Figure 1-1. Edwards Model 150, Model 160 & Model 300 Pumps



Do not perform maintenance using this manual if the model number on the pump is not 150-348 or the serial number is not _____. Performing maintenance using the wrong manual could result in pump failure or personal injury.

Edwards rotary pumps are available in many configurations. While they may look alike, there may be significant differences from one pump to another. Differences include construction material, sealing method, rotor type, etc. This manual covers only one configuration, which is defined by a model number and a serial number. Check the name plate on the pump to make certain the model number is 150-348 and the serial number is _____. If the numbers do not match, contact Edwards - Pentair Water.

Most pump repairs can be performed by maintenance personnel using normally available tools.

Consumable Materials

Cleaning materials, lubricants, and other products needed during pump maintenance are listed in Table 2-1.

Table 2-1. Consumable Materials

Item	Nomenclature	Specification	Common Name
1	Lint-Free Cloth	MIL-C-85043	
2	“Dry” Cleaning Solvent		Acetone, Brake Cleaner
3	Emery Cloth	220 Grit	3M, Anderson, Sandvik, Mirka
4	Anti-Seize Compound		“Nev’r Seize”
5	Red Loctite		PermaLoc HH-120
6	High-Tack Gasket Spray		Loctite, Permatex

Table 2-1. Consumable Materials (Continued)

Item	Nomenclature	Specification	Common Name
7	General Purpose Grease	MIL-G-18709 NLGI #2	Chevron Ulti-Plex, Shell Retina LC
8	Lapping Compound	D51804, 180 Grit Silicon Carbide	Felpro "Clover" Brand

Zerk fittings do not have check balls. This prevents bearings from being over-greased. Excess grease will run out of the fitting when pump is in operation.

Lubrication

To ensure a long service life, the pump should be lubricated routinely with approved grease (7, Table 2-1). If the pump is operating under normal loads and temperatures, use the intervals defined in Table 2-2. If the pump is operating at over 180°F, contact Edwards for recommended lubrication interval for your application.

Table 2-2. Lubrication Schedule

Item	Interval	Amount of Grease
Bearings	4,000 Hours	0.54 Ounce
Timing Gears	4,000 Hours	2.16 Ounce

Troubleshooting

Table 2-3 provides assistance in diagnosing and correcting malfunctions that may occur during normal operation.

Table 2-3. Troubleshooting

Trouble	Probable Cause	Remedial Action
1. Pump does not turn	1a. Seized pump. 1b. Faulty or misaligned coupling. 1c. Damaged or missing shaft key.	1a. Repair or replace pump. 1b. Replace or realign coupling. 1c. Replace key.
2. Excessive Noise	2a. Loose or misaligned coupling. 2b. Cavitation.	2a. Tighten, align, or replace coupling. 2b. Check suction piping with a vacuum gauge. Gauge should read less than 10-in. Hg in most cases. Contact Edwards for the exact reading for your application.

The pump has heat-treated steel timing gears, which can be very noisy when operated above 900 rpm. This is a normal condition, and does not require maintenance action.

Table 2-3. Troubleshooting (Continued)

Trouble	Probable Cause	Remedial Action
	2c. Worn or damaged bearing(s).	2c. Repair or replace pump.
3. Excessive vibration	3a. Loose or misaligned coupling. 3b. Cavitation. 3c. Worn or damaged bearing(s).	3a. Tighten, align, or replace coupling. 3b. Check suction piping with a vacuum gauge. Gauge should read less than 10-in. Hg in most cases. Contact Edwards for the exact reading for your application. 3c. Repair or replace pump.
4. Reduced flow	4a. Clogged suction screen. 4b. Cavitation. 4c. Pump liners and/or rotors worn or damaged. 4d. Low pump speed	4a. Clean or replace screen. 4b. Check suction piping with a vacuum gauge. Gauge should read less than 10-in. Hg in most cases. Contact Edwards for the exact reading for your application. 4c. Repair or replace pump. 4d. Increase pump speed.

Removal



To avoid injury, always de-energize the input driver and lock-out or red-tag the controller. Let the pump cool before removing.

1. Before removing pump, refer to troubleshooting chart (Table 2-3) to determine if the problem is actually the pump.
2. Ensure adequate clearance exists for removal of pump. Disassemble adjacent components as required for adequate working clearance.
3. Before removal, clean exterior parts to remove accumulated dirt, grease, or foreign material.
4. Apply tags to identify parts of similar configuration to ensure correct installation.

Disassembly

General Practice

1. Keep work area as clean as possible to avoid contamination of internal parts.
2. Replace gaskets, packings, and seals removed during repair. Replace all keys, spring washers, and like items during assembly.
3. When removing gaskets, packings, or seals, do not use a metal tool to pry, pick, or scrape. Doing this could scratch sealing surfaces. Use wood or plastic scrapers to remove gasket material.
4. Before disassembly of any component, study exploded view illustration (Figure 4-1). Pay particular attention to relationship of internal parts. Being familiar with construction will speed up disassembly and help avoid improper assembly.
5. To prevent moisture or foreign material from entering open components, install protective plugs or covers as soon as practical after disassembly. Wrap parts in clean paper or clean lint-free cloths (1, Table 2-1).
6. Remove only the parts requiring repair or replacement. Do not disassemble pump any further than necessary to complete needed repairs.

Disassembly Procedure

The pump can be reassembled into several configurations as shown in Figure 2-1. Before disassembling the pump, circle the configuration that matches the pump being repaired. This will be an invaluable aid during reassembly.

1. Remove cap screws (3, Figure 4-1), timing gear cover (2), and cover gasket (4). Discard gasket.
2. Loosen timing gear locknuts (8) and unscrew until locknuts reach end of shaft. This will protect the threads when the timing gears are pulled.
3. Fabricate timing gear puller as shown in Figure 2-2.
4. Install timing gear puller with cap screws on timing gear (10, Figure 4-1). Tighten screws to take up slack and tap puller with a hammer in line with shaft to free timing gear. Repeat procedure for other timing gear.
5. Remove locknuts (8) and timing gears (10).
6. Remove cap screws (6), front cover (5), and cover gasket (4). Discard gasket.
7. Remove front cover seal (7) from front cover (5). Discard seal.
8. Remove setscrews (11) from endcases (15).
9. Remove bearing adjusting nuts (12) from endcases (15).
10. Remove cap screws (16), nuts (18), and washers (17) from drive endcase (15).

When removing the endcases, use two pullers, or alternate one puller between shafts.

The endcase may be pulled off each shaft about 1/8 in. at a time. Alternate the puller between shafts to avoid misalignment during removal.



Do not hammer on pump endcase. This will cause gasket sealing surface damage, resulting in leaks.

Use shaft protector between puller tip and shaft face to prevent distortion of shaft center.

11. Using gear puller, remove drive endcase (15) and pump body gasket (20). Discard gasket.
12. Remove cap screws (16), nuts (18), and washers (17) from timing gear endcase (15).

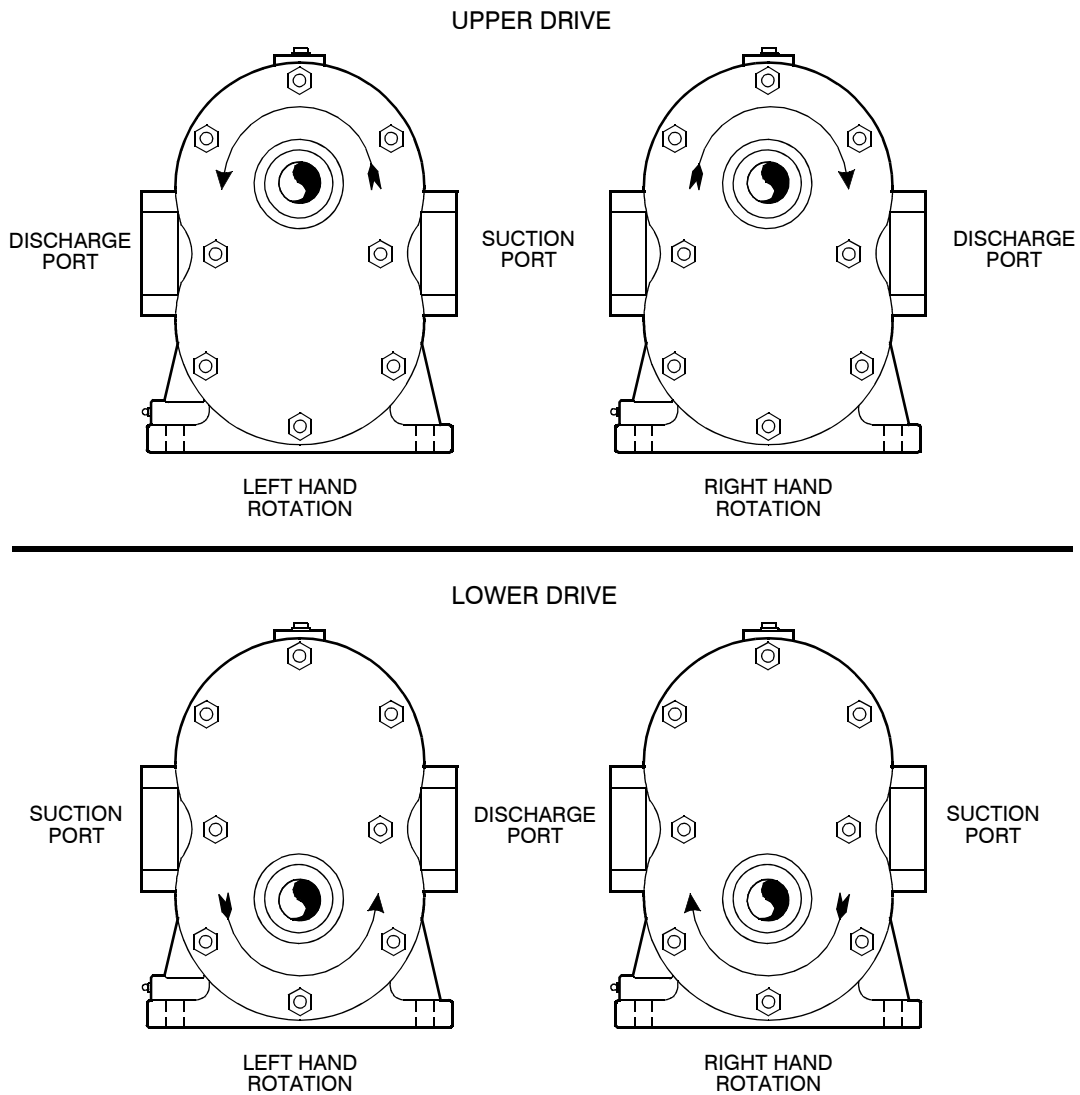

1070_0002a.cdr

NOTE: ALL ROTATIONS ARE VIEWED FROM PUMP SHAFT END.

Edwards USES THE FOLLOWING NOTATION FOR PUMP IDENTIFICATION:

- UR = UPPER SHAFT – RIGHT HAND ROTATION
- UL = UPPER SHAFT – LEFT HAND ROTATION
- LR = LOWER SHAFT – RIGHT HAND ROTATION
- LL = LOWER SHAFT – LEFT HAND ROTATION

Figure 2-1. Pump Configuration Diagram

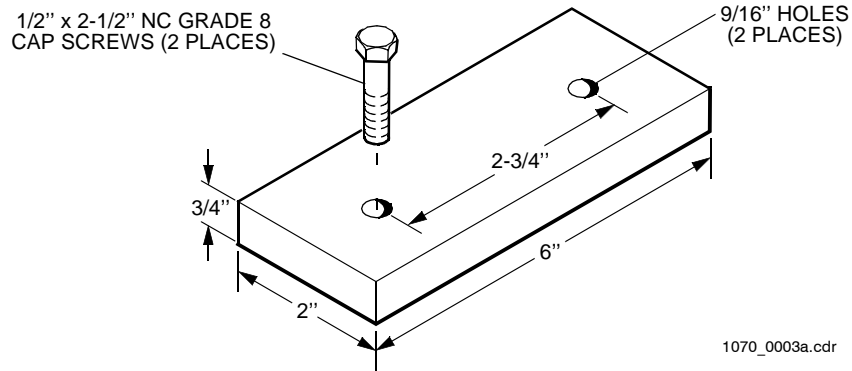

Figure 2-2. Timing-Gear Puller Fabrication Diagram

13. Remove timing gear endcase (15) and pump body gasket (20). Discard gasket.



Never hammer directly on pump drive shaft. This will cause the rotor assembly to become misaligned, resulting in incorrect internal clearances. Also, hammering on the shaft ends may damage the shaft centers.

14. Using hammer and hardwood block, tap pump drive shaft to remove drive and idler rotor assemblies (22 and 23) and two liners (21).
15. Using hammer and hardwood block, remove other liners (21) from pump body (25).
16. If damaged, remove studs (24) from pump body (25).
17. Using hammer and brass drift, remove ball bearings (13) and grease seals (14) from endcases (15).
18. Using hammer and brass drift, remove lip seals (19) from endcases (15).
19. If damaged or plugged, remove grease fittings (1) from endcases (15).
20. If damaged or plugged, remove grease fittings (1) from timing gear cover (2).

Cleaning



Never dip or soak packings, rubber, plastic, or teflon parts in "dry" cleaning solvent. Wipe with clean, lint-free cloth. Solvent can react with material and result in severe damage or destruction of parts.

1. Use "dry" cleaning solvent (2, Table 2-1) to clean parts. Do not use gasoline for cleaning parts.
2. After soaking parts in "dry" cleaning solvent, deposits may be washed away by flushing or spraying. Where necessary, use soft-bristled, non-metallic brush moistened in solvent.
3. Except for bearings, dry parts using filtered, compressed air after cleaning.
4. Unless otherwise noted, do not use metal scrapers, wire brushes, abrasive wheels, or compounds when cleaning parts.

5. Place ball or roller bearings in basket and suspend in container of “dry” cleaning solvent overnight. If necessary, use soft-bristled brush to remove caked grease and chips. Avoid rotating bearing before solid particles are removed to prevent damaging balls and races. After cleaning, dry bearings with low-pressure compressed air.
6. Check all passages and cavities for cleanliness and freedom from foreign material. Use wire brush or pressurized spray gun and “dry” cleaning solvent to clean individual passages.
7. Buff bearing adjusting nut threads (12, Figure 4-1) with a wire brush.

Always replace bearings whenever possible. If new bearings are not available you may clean and inspect the bearings. The bearings may be reused if they are not damaged.

Inspection

1. Check that rotor assemblies and liners are free of radial scoring and heat damage (usually indicated by blue discoloration).
2. Check all surfaces in contact with gaskets, packings, or seals for nicks, burrs, or scratches that may damage new parts during assembly.
3. Visually check castings or weldments for cracks.
4. Check bearings for rusted or pitted balls, races, or cage. Check balls and races for brinelling, abrasions, and discoloration. Excluding defects that may cause bearing binding or misalignment, nicks or gouges outside race load areas are not cause for rejection. Bearings shall be rejected for cuts or grooves parallel to ball or roller rotation, or for fatigue pits (not minor machine marks or scratches).
5. Check all screws, nuts, fittings, and tapped holes for distortion and for stripped or corroded threads.

Repair and Replacement

1. Using fine file or 220 grit emery cloth (3, Table 2-1), remove nicks, burrs, or scratches from surfaces in contact with gaskets, packings, or seals.
2. Using 220 grit emery cloth, remove any buildup on endcase (15, Figure 4-1) counterbore surfaces and inside diameter of pump body (25).
3. Using 220 grit emery cloth or flat file, deburr all edges of pump parts, especially the end covers (2 and 5) and endcases (15).
4. Repair of cracked castings and weldments is not authorized. Replace cracked or damaged parts.
5. Replace all damaged screws, nuts, and fittings. Repair minor damage to tapped holes with same size tap. Do not change size or thread type. Replace all self-locking fasteners.

Take special care to keep gasket surfaces flat and smoothly finished to prevent leakage.

Assembly

General Practice

1. Remove any protective coatings from new parts.
2. Lubricate bearings with same type of lubricant normally used in pump or as directed in specific repair procedure.
3. Lubricate lip of oil seals with lubricant specified in specific procedure. Install oil seals, with lip facing out, by applying an even force to outer edge of seal. We recommend using arbor press to seat the seals.
4. Coat both sides of gaskets with high-tack spray (6, Table 2-1). Be sure all old gaskets and sealant are removed from parts before installing new ones.
5. Hand-thread cap screws into parts until snug, then tighten in criss-cross pattern to final torque. Install all cap screws, nuts, and fasteners using anti-seize compound (4, Table 2-1) unless otherwise indicated in specific procedure.

Assembly Procedure

Assemble Rotors and Liners

1. If removed, install studs (24, Figure 4-1) in pump body (25) using red Loctite (5, Table 2-1). Remove all traces of red Loctite after installing studs.
2. Install liners (21) in pump body (25). Make sure liner suction holes face pump body suction port as shown in Figure 2-3.

If rotors are worn, replace both rotor assemblies.

The suction port of pump body is stamped "Suction" and the discharge port is stamped "Discharge." There are holes drilled in the suction side of the liners.

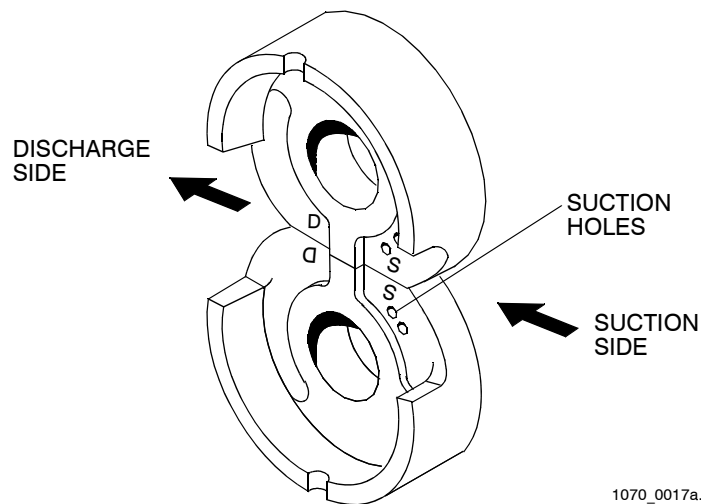

Figure 2-3. Liner Installation



Do not rotate rotor assemblies until bearings have been installed and adjusted. Damage to rotors and liners may occur.

3. Install idler rotor assembly (23, Figure 4-1) in pump body (25) and into liner (21). Make sure threaded end of rotor shaft is away from drive end of pump.
4. Install drive rotor assembly (22) in pump body (25) and into liner (21). Make sure drive rotor shaft is in correct position (Figure 2-1) and threaded end of rotor shaft is away from drive end of pump.
5. Install second set of liners (21, Figure 4-1) in pump body (25). Make sure suction holes face pump body suction port.

Install Seals (if pump has lip seals)

1. Lightly coat bores and outside diameters of four lip seals (19, Figure 4-1) with red Loctite (5, Table 2-1).



Do not use excessive force when installing seals. This could deform the seals, causing them to leak. Use approved tools available from Edwards-Pentair Water.

2. Install lip seals (19, Figure 4-1) in seal bores of endcases (15). Press seals all the way to the bottom of the bore as shown in Figure 2-4. We recommend using an arbor press to seat the seals. Installation tools are available from Edwards-Pentair Water.
3. Pre-lubricate grease seals (14) with approved grease (7, Table 2-1).
4. Install grease seals (14, Figure 4-1) in endcases (15) with sealing lip facing toward counterbore of endcase.

Lip seals have two lips on one side and one lip on the other side. The side with two lips must face toward pump body as shown in Figure 2-4.

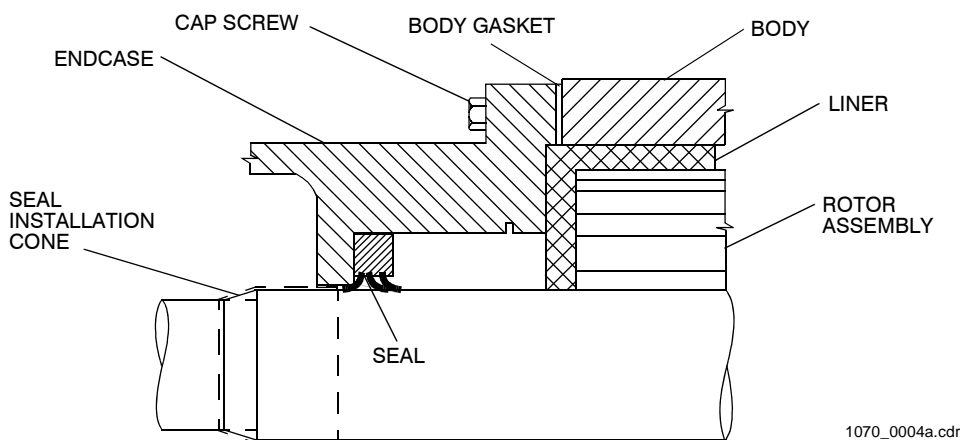

Figure 2-4. Single Lip Seal Installation (Model 160 will have double lip seal arrangement)

Install Endcases

1. Install a new pump body gasket (20) to each side of the body.
2. Install large flat washer and nut (18) on one of the studs (24) on timing-gear end of pump body (25). The outside diameter of the washer must overlap the liners (21) to prevent the liners and rotors from being displaced during installation of the drive-end endcase. Make sure liners are protruding at least 0.2 in. from the body before running the nut and washer up against liners.

Seals must be installed in endcases before installing endcases.

3. Check that seals (19) have been installed in endcase (15) before proceeding with endcase installation.



Make sure liners fit into counterbore on endcase, and that they can be fully seated into the endcase counterbore without using excessive force. Damage to endcases and liners could occur.

We highly recommend you use seal installation cones (available from Edwards) on the rotor shafts during installation of the endcases.

4. Starting with the drive end, carefully install endcase (15) over drive and idler rotor assemblies (22 and 23). Use caution not to damage seals (19).
5. Install cap screws (16), washers (17), and nuts (18) and tighten finger-tight.
6. Remove large washer and nut (18) from timing-gear end of pump body (25).
7. Carefully install other endcase (15) over drive and idler rotor assemblies (22 and 23). Use caution not to damage seals (19).
8. Install cap screws (16), washers (17), and nuts (18) and tighten finger-tight.

Install Bearings

1. Pack ball bearings (13) with approved grease (7, Table 2-1).



Support ends of shafts axially with a jaw puller on the endcase when installing ball bearings to avoid damaging liners and rotors. The jaw puller should be used on the shaft end opposite the end where the bearing is being installed. Use a shaft protector to avoid damaging shaft center.

Bearing installation tools are available from Edwards.

2. Using a bearing seating sleeve, install ball bearings (13, Figure 4-1) on both ends of drive and idler rotor assemblies (22 and 23). Make sure ball bearings are seated on shoulders of shafts with loading grooves facing center of pump.
3. Using criss-cross pattern, tighten cap screws (16) to 35 lb-ft.
4. Using criss-cross pattern, tighten nuts (18) to 25 lb-ft.

Adjust Rotor Clearance

1. Install bearing adjusting nuts (12) on endcases (15), leaving about 1/2-turn short of bearing contact.
2. On idler rotor assembly (23) tighten one bearing adjusting nut (12) until rotor contacts liner (21). Install dial indicator on opposite end of shaft as shown in Figure 2-5 and zero indicator.
3. Loosen previously tightened bearing adjusting nut (12). Tighten opposing bearing adjusting nut until rotor just contacts the other liner and note reading. This is the total clearance.
4. Loosen adjusting nut tightened in step 3 and tighten opposing adjusting nut until dial indicator reading is half the total clearance reading obtained in step 3. (for example, if the total clearance is 0.006 in., adjust for reading of 0.003 in.)
5. Slowly tighten adjusting nut opposing adjusting nut tightened during step 4 until slight opposite dial indicator needle movement is observed. Do not overtighten.

The rotors must be centered between the liners.



Do not overtighten bearing adjusting nut setscrews. Excessive bearing preload may result, causing bearing damage.

6. Tighten the setscrews (11) enough to secure the bearing adjusting nuts (12) in endcase (15).
7. Repeat steps 2 through 6 for drive rotor assembly (22) bearings.

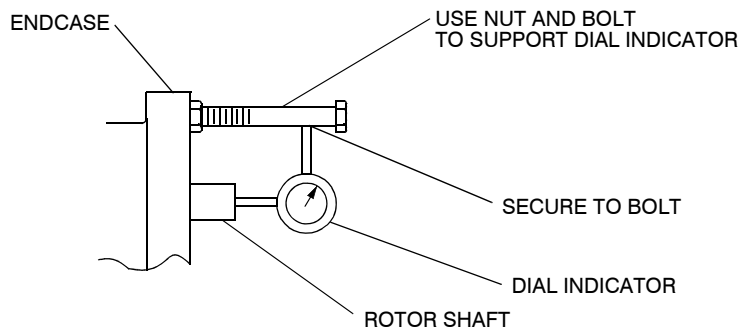

1070_0018a.cdr

Figure 2-5. Rotor Clearance Adjustment

Install Timing Gears

1. Using a lapping compound (8, Table 2-1), lap tapers of timing gears (10, Figure 4-1) to drive and idler rotor shafts (22 and 23), then clean both surfaces with a clean rag and dry-cleaning solvent (2, Table 2-1).
2. Install idler timing gear (10, Figure 4-1) on shaft by tapping gear with a hollow sleeve.
3. Apply anti-seize compound (4, Table 2-10) to timing gear locknut (8, Figure 4-1) threads and install locknut on idler shaft. Wedge a piece of nylon or rawhide between rotors to prevent rotation, and tighten locknut to 175 lb-ft.
4. Insert piece of 0.006- to 0.010-in. shim stock between rotors from the discharge port for lash adjustment. Shim should feed into pump between rotors when drive rotor is turned in normal direction of rotation.
5. Install drive timing gear (10) loosely on shaft, then rotate in direction of normal rotation and mesh both gears. Be careful that shim stock remains in place and that rotation is correct. All backlash between timing gears must be removed before setting gear on taper.
6. Set drive timing gear (10) by tapping gear with a hollow sleeve.
7. Apply anti-seize compound (4, Table 2-10) to timing gear locknut (8, Figure 4-1) threads and install locknut on drive shaft. Wedge a piece of nylon or rawhide between rotors to prevent rotation, and tighten locknut to 175 lb-ft.

8. Remove shim stock and rotate drive rotor (22). The drive rotor should rotate idler rotor (23) freely with no contact between rotors.

Install End Covers

1. Apply light coat of approved grease (7, Table 2-1) to rubber surface of new front cover seal (7, Figure 4-1).
2. Install front cover seal (7) in front cover (5) with seal lips pointed toward inside of cover. We recommend using an arbor press to seat the seal.
3. Apply light coat of approved grease (7, Table 2-1) to front cover gasket surface and install new gasket (4, Figure 4-1), front cover (5), and cap screws (6). Tighten cap screws to 15 to 20 lb-ft.
4. Fill timing gear cover (2) with about three 3/4-in. beads of approved grease (7, Table 2-1) around inside perimeter of cover.
5. Apply light coat of approved grease (7, Table 2-1) to timing gear cover sealing surface and install new gasket (4, Figure 4-1), timing gear cover (2), and cap screws (3). Tighten cap screws to 15 to 20 lb-ft.

Lubricate Bearings

1. If removed, install grease fittings (1) in each endcase (15) and grease fittings (1) in timing gear cover (2).
2. Using grease gun, lubricate pump bearings with approved grease (7, Table 2-1) through endcase grease fittings. Usually five to six pumps is sufficient when bearings have been previously packed.

Replacement

1. Be sure pump is oriented in same position as removed.
2. Check all identifying tags for correct connection of all lines and hoses.
3. Operate pump and inspect for proper adjustment, leaks, vibration, noise, or misalignment. Correct any problems.

Inspection

Edwards pumps are shipped suitably protected to prevent damage in transit from normal handling. When received, inspect the shipment immediately:

1. Check for damage to the packaging or crating and note it on the bill of lading.
2. Check for shipment shortages against the bill of lading.
3. Report shortages to the carrier and note them on the bill of lading.
4. Notify Edwards- Pentair Water of damage to contents not a fault of the carrier, or in the event of shortages.

Unpacking

Care must be taken when removing the pump from the shipping pallet. Remove pump as follows:

1. Remove all protective material.
2. Remove all bolts securing pump to pallet.
3. Using suitable lifting device, lift pump from packing case.
4. Inspect equipment for proper lubrication prior to entering service.

Repacking

1. Using suitable lifting device, lift pump and place on pallet.
2. Secure pump to pallet.
3. Install protective material.

Storage

If the pump will not be installed immediately after receipt and inspection, the pump should be repackaged and placed in suitable storage:

1. Inspect protective coatings on unpainted surfaces. (Do not disturb coatings.)
2. If protective coatings are damaged or if unpainted surfaces are not coated, apply rust inhibiting protective coating to surfaces.

3. Leave plastic or gasket-type port covers in place.
4. If pump comes wrapped with protective material, rewrap pump.
5. Store in clean, dry location.

Installation

The pump can be installed wherever adequate space exists to connect piping and perform maintenance. The pump must be installed in compliance with regulatory body codes (national, state, and local) in effect at the time of installation. In cases where a code conflicts with the following instructions, the code shall prevail.

Clean Pump

To ensure that test fluids and/or preservatives do not contaminate the fluid to be pumped, do the following:

1. Flush pump thoroughly before it is placed in service. The flushing media must be compatible with the pump and seal materials.
2. Remove rust-inhibiting coatings on unpainted exterior surfaces with dry-cleaning solvent (2, Table 2-3).
3. Cover ports and other openings until ready to install piping.

Mount Pump

Install pump on skid base along with the driver as shown in Figure 3-1. See Figure 3-2 for pump dimensions. and Figure 3-3 for mounting bolt locations.

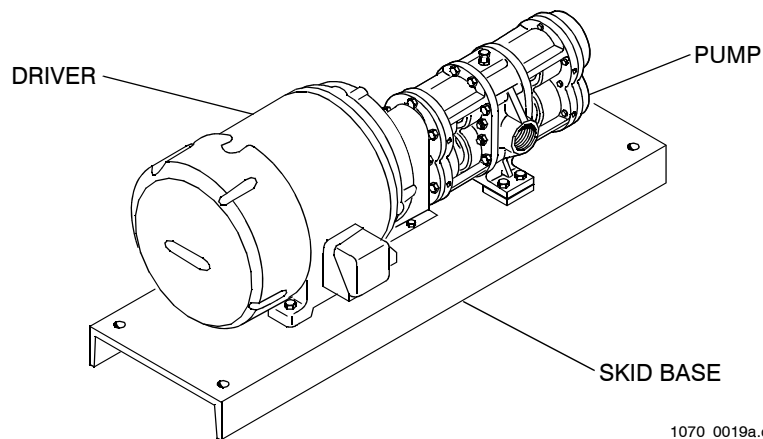

Figure 3-1. Typical Pump Skid

Prepare Foundation

The foundation absorbs any vibration, strains, or shock, while providing a permanent, rigid support for the pump skid.

1. Construct a foundation form that is 4 to 6 inches longer and wider than the skid base. The foundation form height should be about twenty times the diameter of the foundation bolts. See Figure 3-4 for a typical foundation form.
2. Make templates to position and hold foundation bolts in place while pouring concrete.
3. Fasten templates to foundation form.
4. Place form where pump is to be located.
5. Cut four 1.5-inch inside-diameter pipe sleeves 5 inches long.
6. Assemble foundation bolts as shown in Figure 3-5 and attach them to template. Foundation bolts should extend about 2 to 2.5 inches above top of form.
7. Pour a concrete mix of 1:2:4 ratio by volume (cement, fine aggregate, coarse aggregate) into form. Leave surface rough for anchoring grout.

Allow a cure time for the concrete of at least 14 days prior to operation of the pump. A cure time of 28 days is preferred.

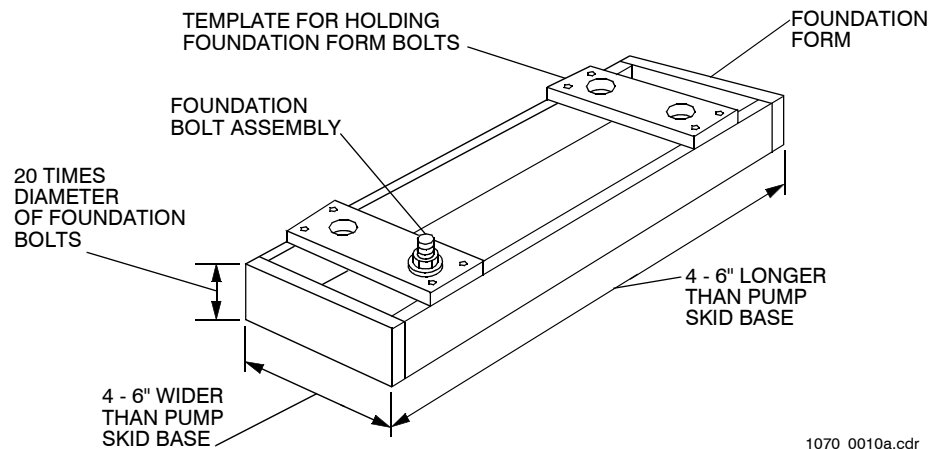

1070_0010a.cdr

Figure 3-4. Typical Foundation Form

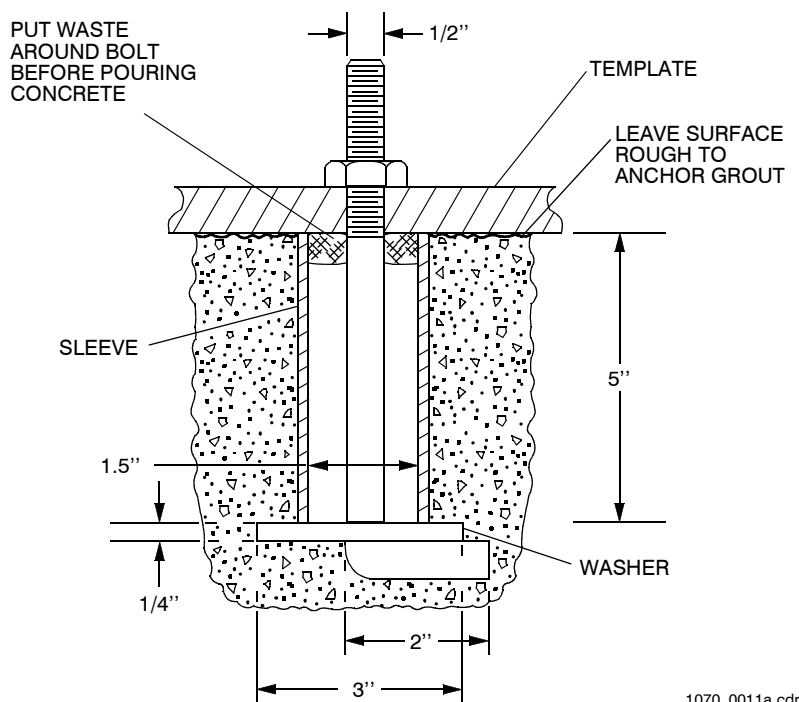

Figure 3-5. Typical Foundation Bolt Configuration

Level Pump Skid

1. Before pump skid is set on foundation, clean underside of skid base and top of foundation.
2. Remove waste from pipe sleeves around foundation bolts.
3. Set leveling pads, either tapered wedge or flat shim plate, adjacent to foundation bolts. Pads should be 1/2 to 3/4 inch total height for grouting as shown in Figure 3-6.
4. Lower pump skid over foundation bolts to rest on leveling pads.
5. Adjust height of leveling pads until base is level and supported at all leveling pad locations.
6. Tighten foundation-bolt nuts finger tight.
7. Double-check level of pump skid.

Grout Pump Skid

The purpose of grouting is to prevent lateral shifting of the skid base, not to take up irregularities in the foundation.

1. Construct wood frame around foundation as shown in Figure 3-6. Set height of the frame to create desired thickness of finished grout.
2. Prepare grout mix of 1:2 ratio by volume (Portland cement and fine sand) with just enough water to obtain creamy consistency and allow free flow under base.

A small spirit level should be used in leveling the pump. Surfaces for determining level in order of preference are the pump flange faces, the pump shaft, projections of machined surfaces on the base and, finally, the surface of the base.

3. Wet top of foundation prior to grouting.
4. Pour grout between frame and skid base.
5. Puddle grout as poured, working as much as possible under skid base and into sleeves around foundation bolts. Ideally, complete space under skid base should be filled to height of grout around skid base.
6. After grout is poured, keep covered with wet burlap for 48 hours to effect slow drying and prevent cracking.
7. When grout is set sufficiently, remove frame and finish grout as desired.
8. Tighten foundation-bolt nuts 72 hours after grouting.

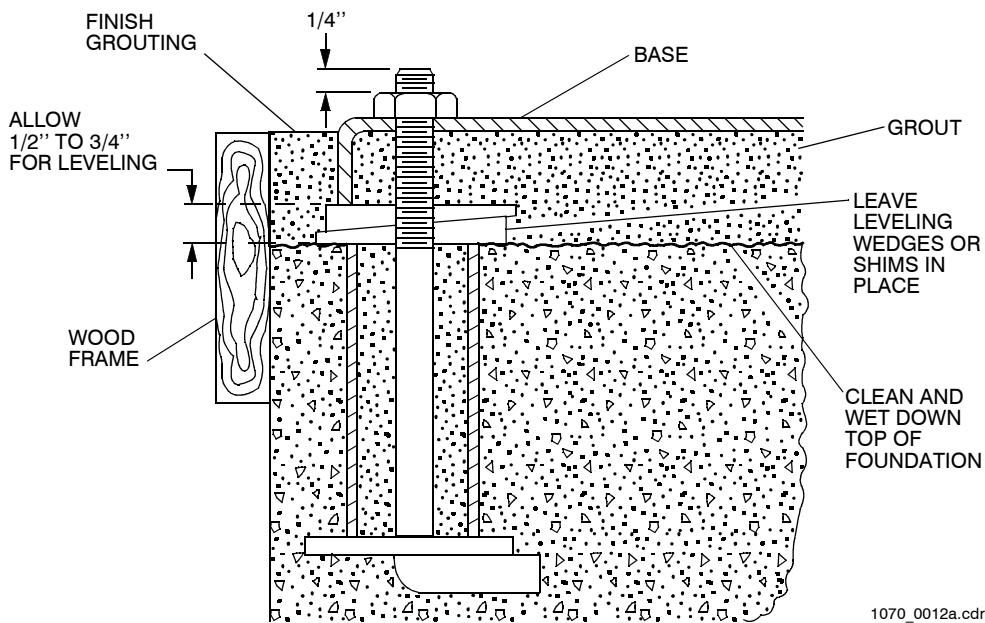

Figure 3-6. Leveling and Grouting Diagram

Since alignment follows the rotation check, we recommend the pump and driver be separated during the rotation check.

Check Driver Rotation

The direction of pump rotation is either clockwise (CW) or counterclockwise (CCW) when viewed from the shaft end of the pump. Pump rotation is specified by a directional arrow designation on the pump as shown in Figure 2-1.

Most pump drivers are induction motors, and direction of rotation is dependent on the connection of the three-phase wire connection. Some drivers, such as unidirectional motors, engines, and turbines, must be carefully checked to ensure that driver direction of rotation matches the pump.

1. Remove coupling safety guards.
2. Remove covers, then remove chain, gear, or steel grid connecting coupling halves.
3. Flex member couplings require loosening of coupling setscrew on one half, sliding coupling half back on shaft, and removing flex member.

4. Start and stop the driver while observing driver shaft rotation. Driver rotation must be same as pump rotation.

Align Couplings

The alignment of the pump and motor or engine driver must be checked before startup. Maximum angular offset in the two coupling halves is 1 degree; maximum parallel offset is 0.015 inch. To align the pump and motor, loosen the mounting bolts, align the two components, and tighten the bolts.

Couplings are intended to provide a mechanically flexible connection for two shaft ends. Additionally, they provide limited shaft end float (for mechanical movement or thermal expansion) and, within prescribed limits, angular and parallel misalignment of shafts. Couplings are not intended to compensate for major angular or parallel misalignment. The allowable misalignment varies with the type of coupling. Refer to the coupling manufacturer's literature for specific allowable limits. Any improvement in alignment beyond the coupling manufacturer's minimum specification will extend pump, mechanical seal or packing, coupling, and driver service life by reducing bearing loads and wear.

Misalignment of the pump and driver shafts may be angular (shaft axes concentric but not parallel), parallel (shaft axes parallel but not concentric), or a combination of the two, as shown in Figure 3-7.

Flexible coupling types in general use are chain, gear, steel grid, and flex member. For aligning the pump and driver shafts, remove the coupling cover, then remove chain, gear, steel grid, or flex member connecting the coupling halves.

For applications where pumps are operated at elevated temperatures, final alignment may not be possible at operating temperature. In this instance, proper allowance should be made for the increase in pump shaft height due to thermal expansion. As a "rule of thumb" (for cast iron or steel pumps), a vertical allowance of 0.001 inch per inch of pump shaft height above the base per 150°F (65°C) should be added to the height of the driver shaft.

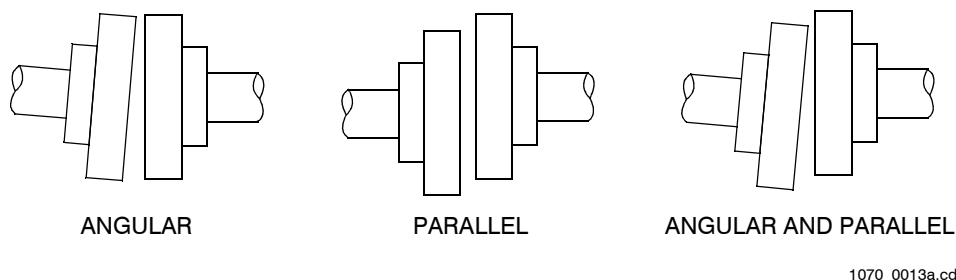

1070_0013a.cdr

Figure 3-7. Types of Coupling Misalignment

Checking for Angular Misalignment. To check angular misalignment:

1. Insert feeler gauge between coupling halves as shown in Figure 3-8.
2. Rotate complete coupling 1/4 turn, 1/2 turn, and 3/4 turn, checking spacing between coupling halves at same location on coupling as in original spacing check. Checking the difference in spacing between coupling halves without rotating the complete coupling may result in an error because coupling faces are sometimes not machined or they may not be square with the centerline of the shaft. The variation in spacing should not exceed the manufacturer's recommendations.
3. Adjust shims under driver or adjust driver location in horizontal plane.

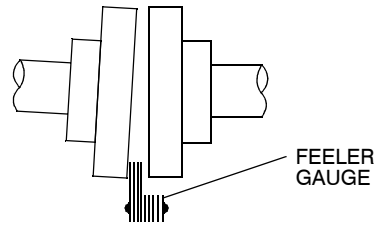

1070_0014a.cdr

Figure 3-8. Checking for Angular Coupling Misalignment

Checking for Parallel Misalignment. To check parallel misalignment:

1. Attach dial indicator as shown in Figure 3-9.
2. With dial indicator secured to pump or driver shaft, rotate both shafts together, noting dial indicator readings through one complete revolution.
3. Adjust shims under driver. Only when absolutely necessary should shims be adjusted or added under pump.
4. If a dial indicator is not available, an alternate check may be made by using a straightedge, as shown in Figure 3-9.
5. Recheck for angular misalignment, which may have resulted when correcting for parallel misalignment.

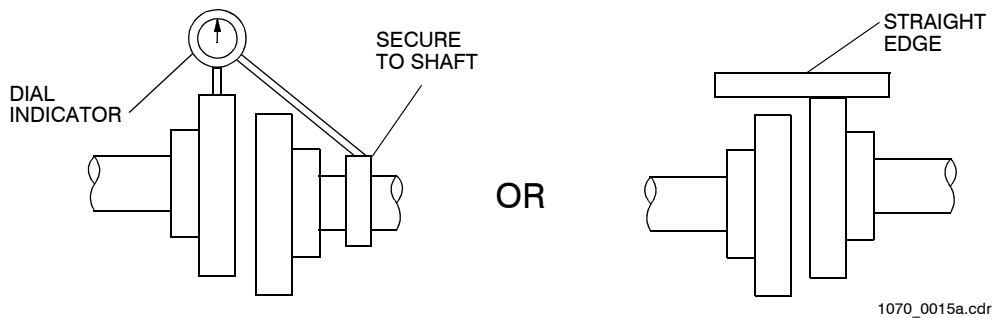

1070_0015a.cdr

Figure 3-9. Checking for Parallel Coupling Misalignment

Checking for Spacer Coupling Misalignment. Spacer-type couplings may be checked for angular and parallel misalignment by the same methods described above, with some minor differences. After the spacer has been removed, the distance between coupling halves requires minor changes to the procedure. For the angular misalignment check, an inside micrometer replaces the feeler gauge. For the parallel misalignment check, a bracket should be attached to one coupling half to support the dial indicator as shown in Figure 3-10.

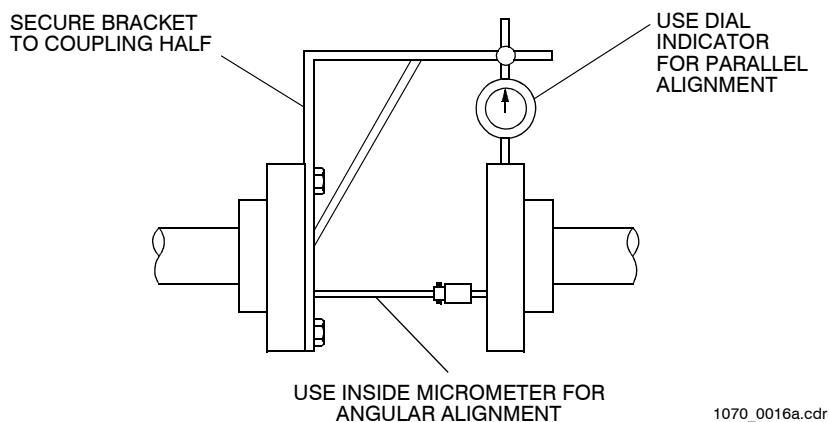

Figure 3-10. Checking for Spacer Coupling Misalignment

Piping



Rotary pumps have close running clearances. Thus, clean piping is a must. Dirt, grit, weld bead or scale, flushed from an unclean piping system, will damage and may stall the pump. Flush the system thoroughly before connecting piping to pump.

Piping should be installed on supports independent of the pump. Supports must be capable of carrying the mass of the pipe, insulation, and the fluid carried. Supports may be hangers or stands that respectively carry the mass from above or below. Clamps or brackets may be used to secure piping to existing columns. Supports must allow for free movement of the piping caused by thermal expansion or contraction. Supports should be installed at intervals such that piping load is uniformly and amply supported, precluding contact with adjacent piping and equipment. Pipe strains or stresses transmitted to the pump by improper piping support systems may cause pump distortion, wear or binding of the rotary members, and excessive power requirements.

Piping systems containing expansion joints must be so designed that the expansion joint is not exposed to motion greater than that for which the joint is designed. Expansion joints or flexible connectors should not be used to compensate for misaligned piping.

Threaded joints should be coated with compounds compatible with but not soluble in the liquid handled. Care must be taken with Teflon-taped joints to prevent shredded pieces of Teflon from entering the piping system. Piping should start at the pump, working toward the source of supply and the point of discharge. Shutoff valves and unions are recommended to facilitate future inspection and repair. Reducers are preferred to bushings when a change in pipe size is necessary. Unnecessary restrictions in the pipeline should be avoided, including elbows, sharp bends, globe or angle valves, and restricted-type plug valves.

Pipe size must take into account the required capacity, minimum or maximum velocities, the fluid viscosity at the lowest pumping temperature, the length of the piping sys-

Do not install 45- or 90-degree fittings at the pump suction port. When possible, provide 10 pipe diameters of straight pipe at the suction port.

tem including valves, strainers, and other restrictions, and the elevation of the pump with reference to supply and discharge points. Friction or line losses may be calculated by referring to the manufacturer's Engineering Manual or the Hydraulic Institute's Engineering Data Book.

Inlet Piping. Inlet piping should normally be equal to or one size larger than the pump inlet port connection. Viscous liquids may require larger inlet piping. Absolute air tightness of the inlet line is a must. Pumps operating with a static suction lift should have the inlet piping sloping gradually upward to the pump. On a long, horizontal run, keep the horizontal piping below the liquid level when possible. Piping should go around obstacles that are encountered rather than over them. Piping over an obstacle creates an air pocket, thereby making priming difficult.

Outlet Piping. Outlet piping should be sized to produce the desired discharge pressure. At the outlet port, the piping should have a vertical rise of about five pipe diameters to prevent gas or air pockets in the pump and act as a fluid seal within the pump on high-vacuum starting.

Strainers

With but a few exceptions, a pump should not be installed without strainer protection. Foreign matter may be large enough or of sufficient volume to jam a pump with probable damage to both pump and drive equipment. Smaller matter passing through the pump will cause rapid pump wear and premature pump failure.

Strainers should be of ample size to prevent an excessive vacuum condition at the pump. Generally, the net area of the strainer screen should be three to five times the area of the inlet pipe. The required net area is dependent on the flow rate and the liquid viscosity. Strainer basket design must include capability of operation under high vacuum without collapsing.

Install the strainer in the inlet piping near the pump, making certain it is located where it may be readily serviced. The strainer must be installed according to arrows or notation designating direction of flow. Provide a vacuum or compound gauge before and after the strainer to determine when cleaning is required.

For continuous pumping, a bypass (including valving) should be piped around the strainer to permit cleaning. Alternately, two strainers in parallel or a duplex strainer may be used.

Check the strainer frequently when the pump is first started. This is the time that foreign material in the system is most likely to collect in the strainer.

Overpressure Protection



Overpressurization of the pump can cause equipment failure, resulting in personal injury.

The pump is capable of building infinite pressure. A pressure relief valve should be installed in the discharge side of the piping as shown in Figure 3-11. The relief valve discharge should be piped back to the supply tank. If it is routed directly to the suction side of the pump, the recirculation will cause excessive heat buildup. This will cause expansion between close-tolerance parts, which will result in galling or binding in the pump.

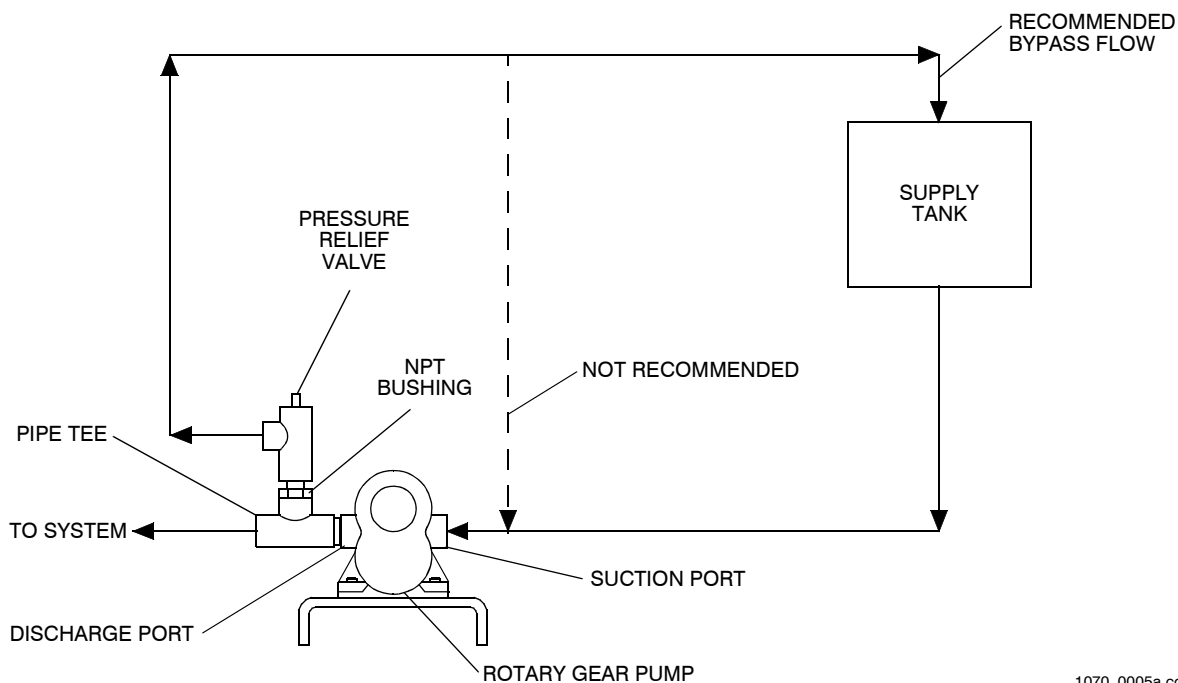

1070_0005a.cdr

Figure 3-11. Pump By-pass Piping

Pre-Startup Checks

Inspection checks are essential to avoid operational difficulties and ensure trouble-free startup. Listed below are several items that need to be checked before the pump is started:

1. Inspect all piping for undue stress and strain on the pump.
2. Flush and leak test all piping before connecting to pump.
3. Fully open inlet and outlet valves. Pump must not be started with throttled or closed inlet or outlet valves.
4. Close all drain valves.
5. Check wiring diagrams for proper connections for voltage and rotation. Proper rotation is indicated by an arrow on the pump. Disconnect driver coupling and start driver momentarily to ensure correct rotation.
6. Before reconnecting driver coupling, turn pump shaft to be sure it rotates freely.
7. Reconnect driver coupling and replace guard. Make certain all other guards are in place.
8. For relief valves that can be installed for either direction of rotation, make certain that valve is installed properly for desired rotation.
9. Install pressure and vacuum gauges for checking startup conditions.



AURORA® EDWARDS SERIES

Parts 4



Do not order parts using this manual if the model number on the pump is not 150-348 or the serial number is not _____. Using parts ordered from the wrong manual could result in pump failure or personal injury.

Edwards rotary pumps are available in many configurations. While they may look alike, there may be significant differences from one pump to another. Differences include construction material, sealing method, rotor type, etc. This manual covers only one configuration, which is defined by a model number and a serial number. Check the name plate on the pump to make certain the model number is 150-348 and the serial number is _____. If the numbers do not match, contact Edwards - Pentair Water.

When ordering parts, please provide:

1. Pump Type
2. Pump Size
3. Pump Serial Number
4. Piece Number from the exploded view in this manual or from the Repair Parts Index
5. Quantity Needed

Order replacement parts from:

Pentair
800 Airport Road,
North Aurora, IL 60542

phone: 630-859-7000
fax: 630-859-1226
website: www.aurorapump.com

Figure 4-1. Edwards Model 150 Pump Exploded View

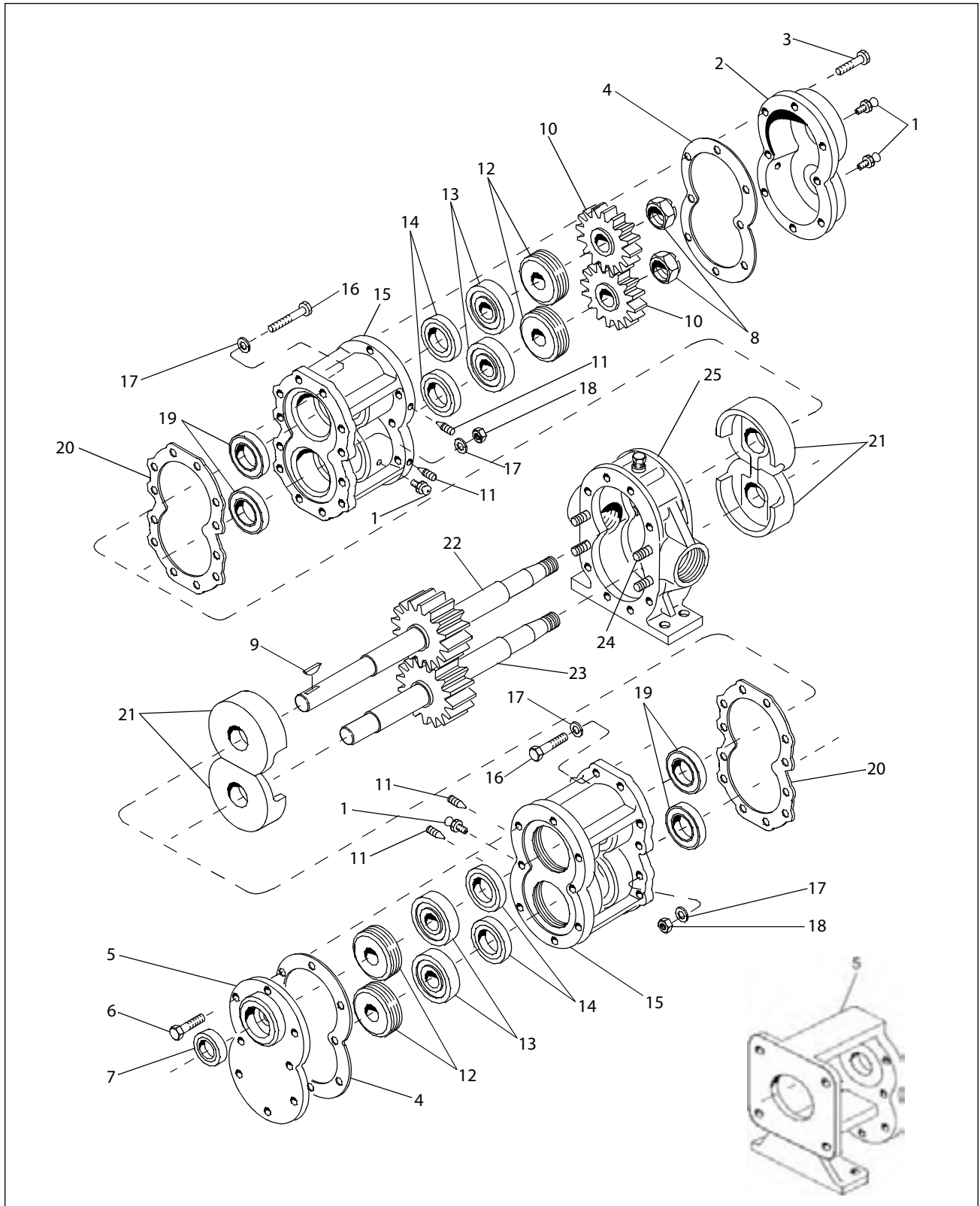

Figure 4-2. Edwards Model 160 Pump Exploded View

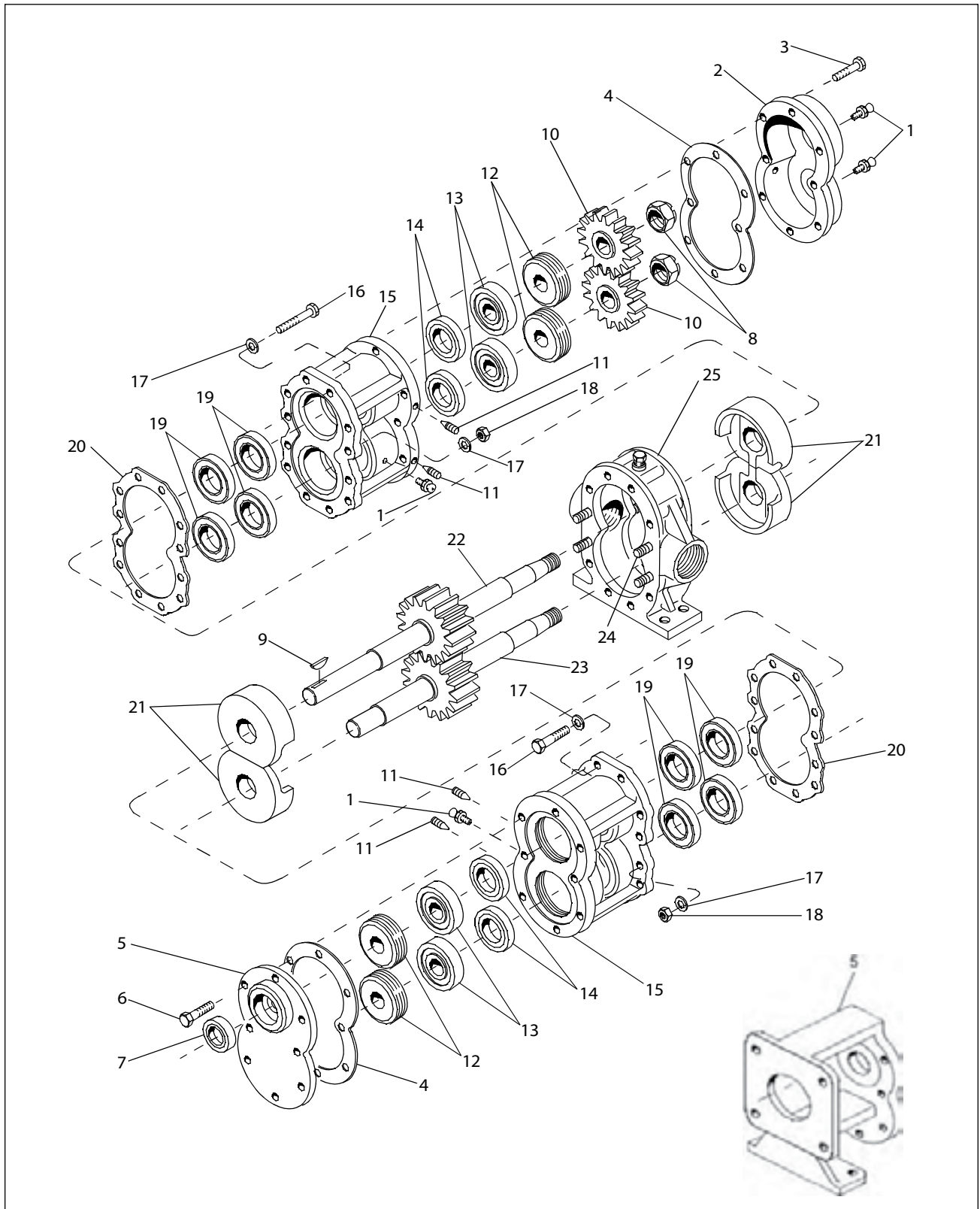
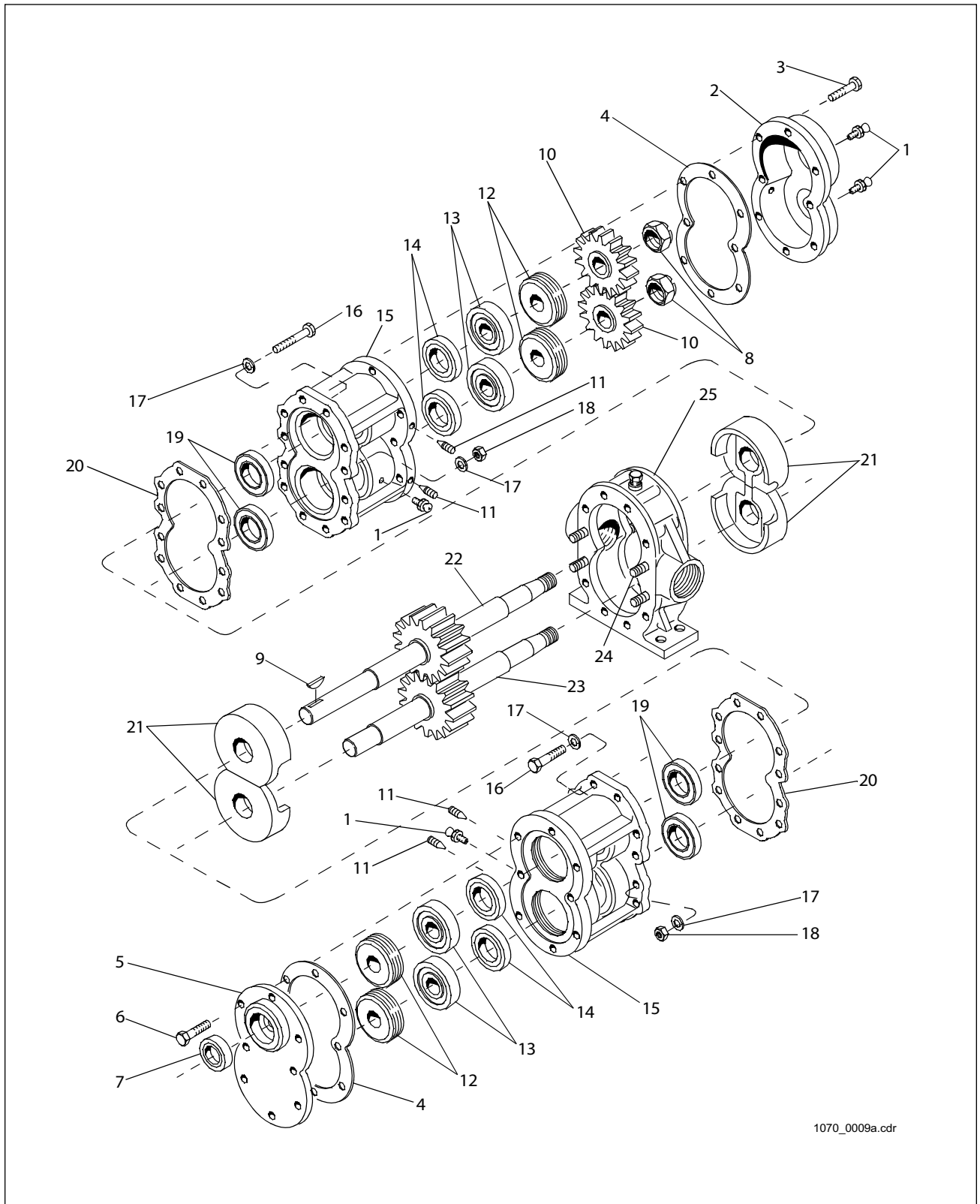

Figure 4-3. Edwards Model 300 Pump Exploded View



1070_0009a.cdr



AURORA® EDWARDS SERIES

WARRANTY: Seller warrants equipment (and its component parts) of its own manufacture against defects in materials and workmanship under normal use and service for one (1) year from the date of installation or start-up, or for eighteen (18) months after the date of shipment, whichever occurs first. Seller does not warrant accessories or components that are not manufactured by Seller; however, to the extent possible, Seller agrees to assign to Buyer its rights under the original manufacturer's warranty, without recourse to Seller. Buyer must give Seller notice in writing of any alleged defect covered by this warranty (together with all identifying details, including the serial number, the type of equipment, and the date of purchase) within thirty (30) days of the discovery of such defect during the warranty period. No claim made more than 30 days after the expiration of the warranty period shall be valid. Guarantees of performance and warranties are based on the use of original equipment manufactured (OEM) replacement parts. Seller assumes no responsibility or liability if alterations, non-authorized design modifications and/or non-OEM replacement parts are incorporated if requested by Seller, any equipment (or its component parts) must be promptly returned to Seller prior to any attempted repair, or sent to an authorized service station designated by Seller, and Buyer shall prepay all shipping expenses. Seller shall not be liable for any loss or damage to goods in transit, nor will any warranty claim be valid unless the returned goods are received intact and undamaged as a result of shipment. Repaired or replaced material returned to customer will be shipped F.O.B., Seller's factory. Seller will not give Buyer credit for parts or equipment returned to Seller, and will not accept delivery of any such parts or equipment, unless Buyer has obtained Seller's approval in writing. The warranty extends to repaired or replaced parts of Seller's manufacture for ninety (90) days or for the remainder of the original warranty period applicable to the equipment or parts being repaired or replaced, whichever is greater. This warranty applies to the repaired or replaced part and is not extended to the product or any other component of the product being repaired. Repair parts of its own manufacture sold after the original warranty period are warranted for a period of one (1) year from shipment against defects in materials and workmanship under normal use and service. This warranty applies to the replacement part only and is not extended to the product or any other component of the product being repaired. Seller may substitute new equipment or improve part(s) of any equipment judged defective without further liability. All repairs or services performed by Seller, which are not covered by this warranty, will be charged in accordance with Seller's standard prices then in effect.

THIS WARRANTY IS THE SOLE WARRANTY OF SELLER AND SELLER HEREBY EXPRESSLY DISCLAIMS AND BUYER WAIVES ALL OTHER WARRANTIES EXPRESSED, IMPLIED IN LAW OR IMPLIED IN FACT, INCLUDING ANY WARRANTIES OF MERCHANTABILITY OR FITNESS FOR A PARTICULAR PURPOSE. Seller's sole obligation under this warranty shall be, at its option, to repair or replace any equipment (or its component parts) which has a defect covered by this warranty, or to refund the purchase price of such equipment or part. Under the terms of this warranty, Seller shall not be liable for (a) consequential, collateral, special or liquidated losses or damages; (b) equipment conditions caused by normal wear and tear, abnormal conditions of use, accident, neglect, or misuse of said equipment; (c) the expense of, and loss or damage caused by, repairs or alterations made by anyone other than the Seller; (d) damage caused by abrasive materials, chemicals, scale deposits, corrosion, lightning, improper voltage, mishandling, or other similar conditions; (e) any loss, damage, or expense relating to or resulting from installation, removal or reinstallation of equipment; (f) any labor costs or charges incurred in repairing or replacing defective equipment or parts, including the cost of reinstalling parts that are repaired or replaced by Seller; (g) any expense of shipment of equipment or repaired or replacement parts; or (h) any other loss, damage or expense of any nature.

The above warranty shall not apply to any equipment which may be separately covered by any alternate or special warranties.

PERFORMANCE: In the absence of Certified Pump Performance Tests, equipment performance is not warranted or guaranteed. Performance curves and other information submitted to Buyer are approximate and no warranty or guarantee shall be deemed to arise as a result of such submittal. All testing shall be done in accordance with Seller's standard policy under Hydraulic Institute procedures.

LIABILITY LIMITATIONS: Under no circumstances shall the Seller have any liability under the Order or otherwise for liquidated damages or for collateral, consequential or special damages or for loss of profits, or for actual losses or for loss of production or progress of construction, regardless of the cause of such damages or losses. In any event, Seller's aggregate total liability under the Order or otherwise shall not exceed the contract price.

ACTS OF GOD: Seller shall in no event be liable for delays in delivery of the equipment or other failures to perform caused by fires, acts of God, strikes, labor difficulties, acts of governmental or military authorities, delays in transportation or procuring materials, or causes of any kind beyond Seller's control.

COMPLIANCE WITH LAW: Seller agrees to comply with all United States laws and regulations applicable to the manufacturing of the subject equipment. Such compliance shall include: The Fair Labor Standards Acts of 1938, as amended; Equal Employment Opportunity clauses of Executive Order 11246, as amended; Occupational Safety and Health Act of 1970 and the standards promulgated thereunder, if applicable. Since compliance with the various Federal, State, and Local laws and regulations concerning occupational health and safety, pollution or local codes are affected by the use, installation and operation of the equipment and other matters over which Seller has no control, Seller assumes no responsibility for compliance with those laws and regulations, whether by way of indemnity, warranty, or otherwise. It is incumbent upon the Buyer to specify equipment which complies with local codes and ordinances.



AURORA® EDWARDS SERIES



AURORA® EDWARDS SERIES

800 Airport Road,
North Aurora, IL 60542
phone: 630-859-7000
fax: 630-859-1226
website: www.aurorapump.com

ED11008 (07/08/13)